

### AT 10 (Teilung = 10 mm) – für Zahnriemenbreite = 25 mm

Artikel-Nr. Ketten Fuchs	Zähne- zahl	Typ	Werk- stoff	Abmessungen in mm							
				de	dp	dm	Di	df	W	L	D1
40AT10/15-2	15	6F	Al	45,90	47,75	32,0	–	51,0	30,0	40,0	8,0
40AT10/16-2	16	6F	Al	49,05	50,93	35,0	–	54,0	30,0	40,0	8,0
40AT10/18-2	18	6F	Al	55,45	57,29	40,0	–	60,0	30,0	40,0	8,0
40AT10/19-2	19	6F	Al	58,60	60,48	44,0	–	66,5	30,0	40,0	8,0
40AT10/20-2	20	6F	Al	61,80	63,66	46,0	–	66,5	30,0	40,0	8,0
40AT10/22-2	22	6F	Al	68,15	70,03	52,0	–	75,0	30,0	40,0	8,0
40AT10/24-2	24	6F	Al	74,55	76,39	58,0	–	83,0	30,0	40,0	8,0
40AT10/25-2	25	6F	Al	77,70	79,58	60,0	–	83,0	30,0	40,0	8,0
40AT10/26-2	26	6F	Al	80,90	82,76	60,0	–	87,0	30,0	40,0	8,0
40AT10/27-2	27	6F	Al	84,10	85,95	60,0	–	91,0	30,0	40,0	8,0
40AT10/28-2	28	6F	Al	87,25	89,12	60,0	–	93,0	30,0	40,0	8,0
40AT10/30-2	30	6F	Al	93,65	95,49	60,0	–	102,0	30,0	40,0	8,0
40AT10/32-2	32	6F	Al	100,00	101,86	65,0	–	106,0	30,0	40,0	10,0
40AT10/36-2	36	6F	Al	112,75	114,59	70,0	–	119,0	30,0	40,0	10,0
40AT10/40-2	40	6F	Al	125,45	127,32	80,0	–	131,0	30,0	40,0	10,0
40AT10/44-0	44	6	Al	138,20	140,05	88,0	–	–	30,0	40,0	10,0
40AT10/48-0	48	6	Al	150,95	152,78	95,0	–	–	30,0	40,0	16,0
40AT10/60-0	60	6	Al	189,10	190,98	110,0	–	–	30,0	40,0	16,0

### Zahnriemenscheiben (metrische AT-Teilung)

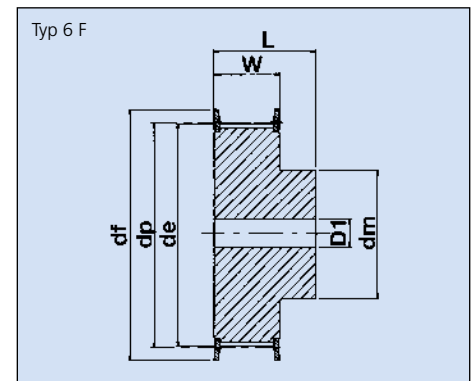
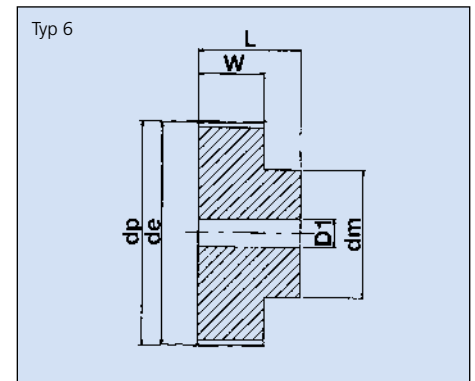

### AT 10 (Teilung = 10 mm) – für Zahnriemenbreite = 32 mm

Artikel-Nr. Ketten Fuchs	Zähne- zahl	Typ	Werk- stoff	Abmessungen in mm							
				de	dp	dm	Di	df	W	L	D1
47AT10/18-2	18	6F	Al	55,45	57,29	40,0	–	60,0	37,0	47,0	10,0
47AT10/19-2	19	6F	Al	58,60	60,48	44,0	–	66,5	37,0	47,0	10,0
47AT10/20-2	20	6F	Al	61,80	63,66	46,0	–	66,5	37,0	47,0	12,0
47AT10/22-2	22	6F	Al	68,15	70,03	52,0	–	75,0	37,0	47,0	12,0
47AT10/24-2	24	6F	Al	74,55	76,39	58,0	–	83,0	37,0	47,0	12,0
47AT10/25-2	25	6F	Al	77,70	79,58	60,0	–	83,0	37,0	47,0	12,0
47AT10/26-2	26	6F	Al	80,90	82,76	60,0	–	87,0	37,0	47,0	12,0
47AT10/27-2	27	6F	Al	84,10	85,95	60,0	–	91,0	37,0	47,0	12,0
47AT10/28-2	28	6F	Al	87,25	89,12	60,0	–	93,0	37,0	47,0	12,0
47AT10/30-2	30	6F	Al	93,65	95,49	60,0	–	102,0	37,0	47,0	12,0
47AT10/32-2	32	6F	Al	100,00	101,86	65,0	–	106,0	37,0	47,0	12,0
47AT10/36-2	36	6F	Al	112,75	114,59	70,0	–	119,0	37,0	47,0	16,0
47AT10/40-2	40	6F	Al	125,45	127,32	80,0	–	131,0	37,0	47,0	16,0
47AT10/44-0	44	6	Al	138,20	140,05	88,0	–	–	37,0	47,0	16,0
47AT10/48-0	48	6	Al	150,95	152,78	95,0	–	–	37,0	47,0	16,0
47AT10/60-0	60	6	Al	189,10	190,98	110,0	–	–	37,0	47,0	16,0

### AT 10 (Teilung = 10 mm) – für Zahnriemenbreite = 50 mm

Artikel-Nr. Ketten Fuchs	Zähne- zahl	Typ	Werk- stoff	Abmessungen in mm							
				de	dp	dm	Di	df	W	L	D1
66AT10/18-2	18	6F	Al	55,45	57,29	40,0	–	60,0	56,0	66,0	10,0
66AT10/19-2	19	6F	Al	58,60	60,48	44,0	–	66,5	56,0	66,0	10,0
66AT10/20-2	20	6F	Al	61,80	63,66	46,0	–	66,5	56,0	66,0	12,0
66AT10/22-2	22	6F	Al	68,15	70,03	52,0	–	75,0	56,0	66,0	12,0
66AT10/24-2	24	6F	Al	74,55	76,39	58,0	–	83,0	56,0	66,0	12,0
66AT10/25-2	25	6F	Al	77,70	79,58	60,0	–	83,0	56,0	66,0	12,0
66AT10/26-2	26	6F	Al	80,90	82,76	60,0	–	87,0	56,0	66,0	12,0
66AT10/27-2	27	6F	Al	84,10	85,95	60,0	–	91,0	56,0	66,0	12,0
66AT10/28-2	28	6F	Al	87,25	89,12	60,0	–	93,0	56,0	66,0	12,0
66AT10/30-2	30	6F	Al	93,65	95,49	60,0	–	102,0	56,0	66,0	12,0
66AT10/32-2	32	6F	Al	100,00	101,86	65,0	–	106,0	56,0	66,0	12,0
66AT10/36-2	36	6F	Al	112,75	114,59	70,0	–	119,0	56,0	66,0	16,0
66AT10/40-2	40	6F	Al	125,45	127,32	80,0	–	131,0	56,0	66,0	16,0
66AT10/44-0	44	6	Al	138,20	140,05	88,0	–	–	56,0	66,0	16,0
66AT10/48-0	48	6	Al	150,95	152,78	95,0	–	–	56,0	66,0	16,0
66AT10/60-0	60	6	Al	189,10	190,98	110,0	–	–	56,0	66,0	16,0